

Heating Immersion Circulator

MP

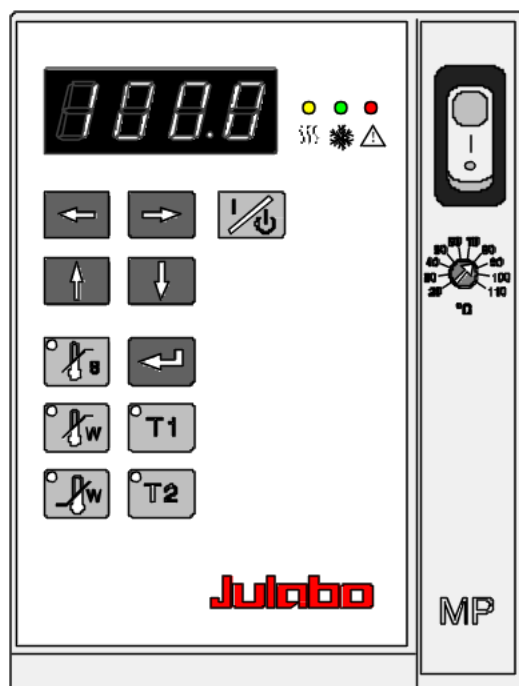

1.951.0703BE2 01/03



Congratulations!

You have made an excellent choice.

Julabo thanks you for the trust you have placed in us.

This operating manual has been designed to help you gain an understanding of the principles of operating and possibilities of our circulators. For optimum utilization of all functions, we recommend that you thoroughly study this manual prior to beginning operation.

Safety Warnings

Take care your unit is operated only by qualified persons.

Make sure you read and understand all instructions and safety precautions listed in this manual before installing or operating your unit. If you have any questions concerning the operation of your unit or the information in this manual, contact JULABO.

Performance of installation, operation, or maintenance procedures other than those described in this manual may result in a hazardous situation and may void the manufacturer's warranty.

Transport the unit with care. Sudden jolts or drops may cause damages in the interior of the unit.

Observe all warning labels.

Never remove warning labels.

Never operate damaged or leaking equipment.

Never operate the unit without bath fluid in the bath.

Always turn off the unit and disconnect the mains cable from the power source before performing any service or maintenance procedures, or before moving the unit.

Always empty the bath before moving the unit.

Never operate equipment with damaged mains power cables.

Refer service and repairs to a qualified technician.









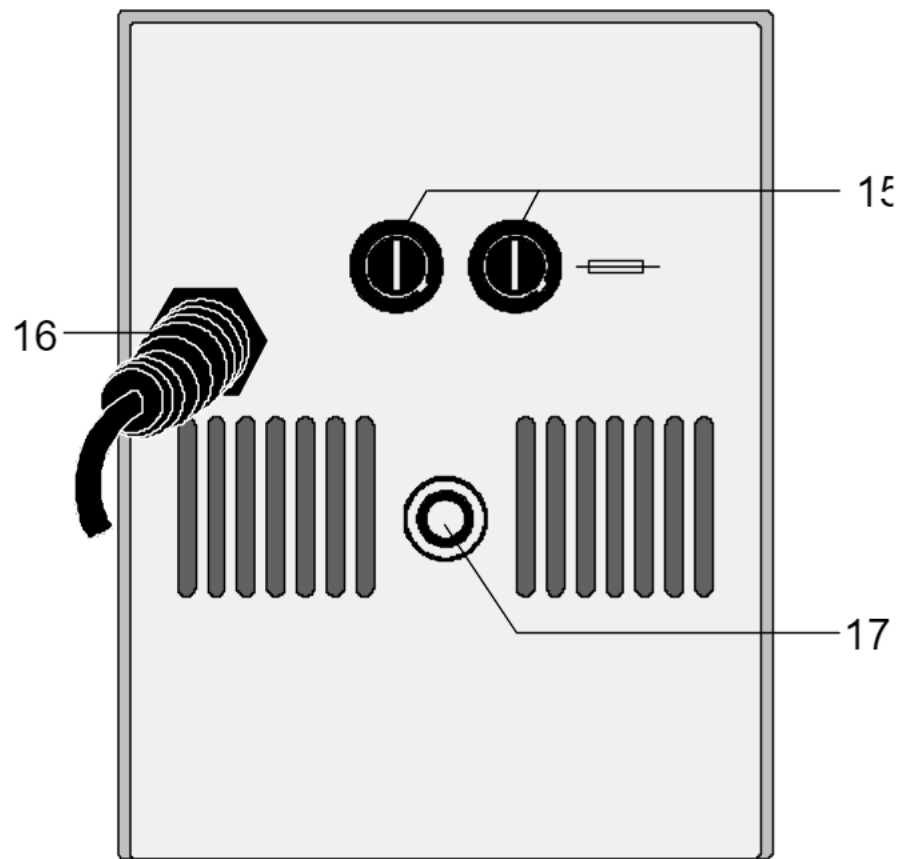
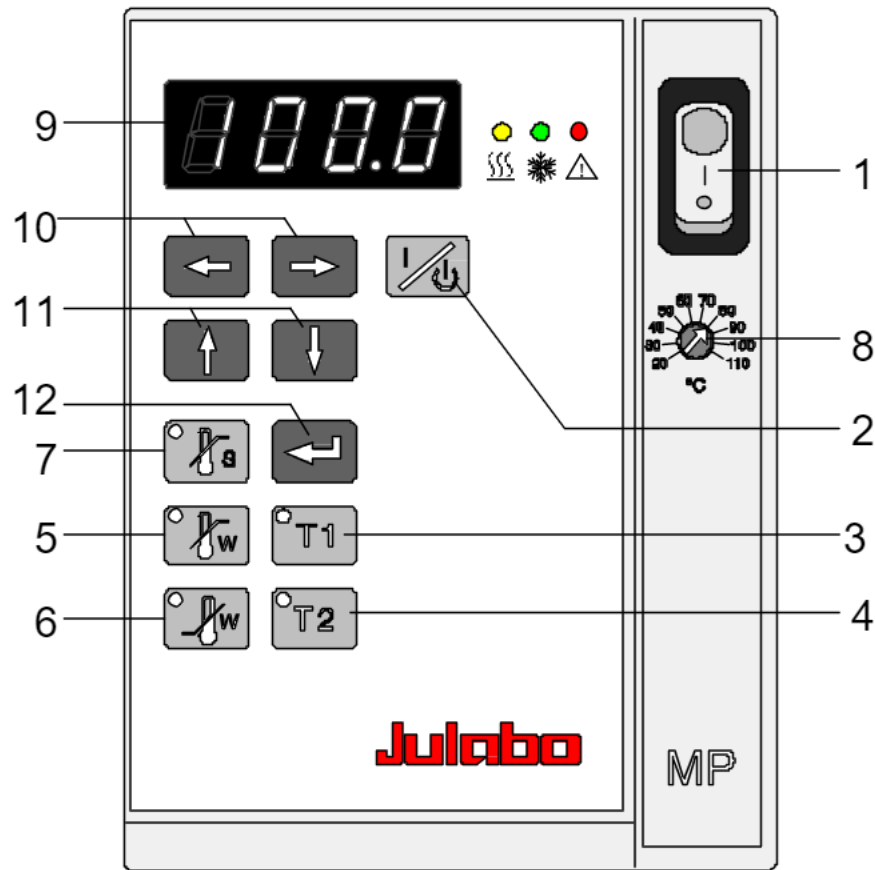







In addition to the safety warnings listed above, warnings are posted throughout the manual. These warnings are designated by an exclamation mark inside an equilateral triangle. Read and follow these important instructions. Failure to observe these instructions can result in permanent damage to the unit, significant property damage, personal injury or death.

TABLE OF CONTENTS

1. Operating controls and functional elements	5
2. Quality Management System	6
3. Unpacking and checking	6
4. Description.....	6
5. Preparations	7
5.1. Installation.....	7
5.2. Bath liquids / Tubing	7
5.3. Countercooling	8
5.4. Temperature application to external systems.....	9
5.5. Adjusting the pump flow	10
6. Operating procedures.....	11
6.1. Power connection.....	11
6.2. Switching on / Start - Stop	11
6.3. Setting the temperatures.....	13
6.4. Warning functions	14
6.5. Safety installations (with shutdown function)	15
7. Troubleshooting guide / Error messages	16
8. Safety recommendations	17
9. ATC - Absolute Temperature Calibration.....	18
10. Cleaning the unit.....	19
11. Maintenance	19
12. Technical specifications	20
13. EC Declaration of Conformity.....	22
14. Warranty conditions	23



1. Operating controls and functional elements

- 1  Mains power switch, illuminated
- 2  Start / stop key
- 3  Working temperature T1
- 4  Working temperature T2
- 5  High temperature warning limit
- 6  Low temperature warning limit
- 7  Safety temperature
- 8  Adjustable excess temperature protection
(safety temperature)
- 9  MULTI-DISPLAY (LED) temperature indication
- 10  Cursors left/right
- 11  Edit keys (increase/decrease setting)
- 12  Enter key (store)
-  Indicator light - Alarm
-  Indicator light - Cooling (not operational)
-  Indicator light - Heating
- 15 Mains fuses, fuse holders
- 16 Mains power cable with plug
- 17 Threaded fitting (10 mm) for stand rod attachment

2. Quality Management System



The JULABO Quality Management System:

Development, production and distribution of temperature application instruments for research and industries conform to the requirements according to DIN EN ISO 9001:1994-08.

Certificate Registration No. QA 051004008.

3. Unpacking and checking

Unpack the circulator and accessories and check for damages incurred during transit. These should be reported to the responsible carrier, railway, or postal authority, and a request for a damage report should be made. These instructions must be followed fully for us to guarantee our full support of your claim for protecting against loss from concealed damage. The form required for filing such a claim will be provided by the carrier.

4. Description

The JULABO circulators are suitable for temperature application to liquids in a bath tank.

The main functional elements are the heater, circulation pump, and control electronics. An electronic proportional temperature control (PID characteristic) adapts the heat supplied to the thermal requirements of the bath.

Setting is rapid and simple using the keypad with its easy to learn symbols. Keypad is splash-proof, easily cleaned and ergonomically designed.

The microprocessor technology allows four temperature values to be stored and indicated on the MULTI-DISPLAY (LED): working temperatures T1 and T2, high and low temperature warning limits.

The safety value for excess temperature protection, a safety installation independent from the control circuit, is adjustable on the front and visible on the MULTI-DISPLAY (LED).

The circulator conforms to the safety requirements specified by DIN 12 876 (safety class 1), as well as DIN 58 966, the guideline for first voltage range EN 61010.

5. Preparations

5.1. Installation

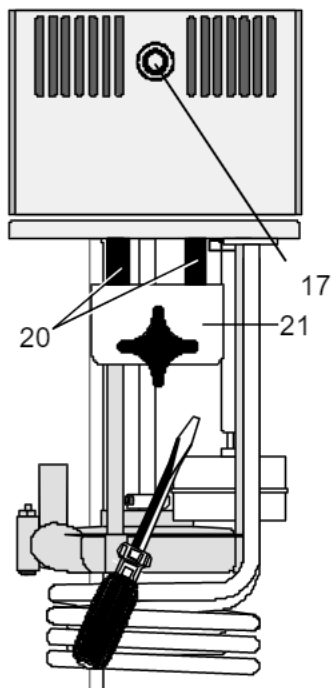

Heating immersion circulator

The heating immersion circulator is mounted using a bath attachment clamp (21) designed for bath wall thicknesses up to 26 mm.

Use the two sleeves (20) supplied with the unit to reduce the immersion depth from 165 mm to 145 mm (see drawing).

For use with glass vessels an upright stand rod (order no. 8 970 020), available as optional accessory, may be screwed in the threaded fitting (17).

5.2. Bath liquids / Tubing

- Recommended bath liquid: deionized water.



No liability for use of other bath liquids!

- Recommended tubing:
CR (Chloroprene) tubing
(temperature range -20 °C to +120 °C)

5.3. Countercooling

For applications near the ambient temperature, the cooling coil (order no. 8 970 105) must be connected to the water mains.

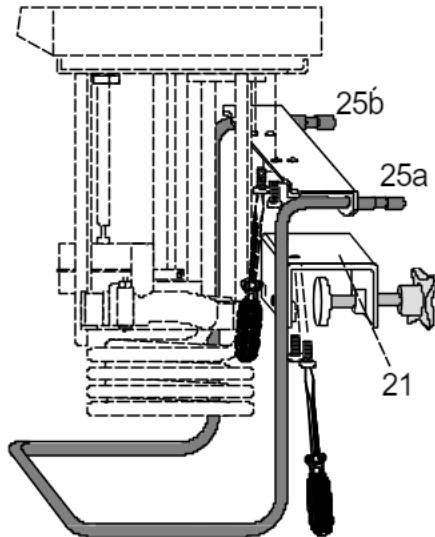

Mounting the cooling coil:

- Remove the bath attachment clamp (21).
- Screw the cooling coil to the circulator, and then fix the bath attachment clamp to the cooling coil.
- Thus the total immersion depth is reduced to 145 mm.

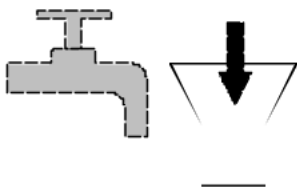

Using tubing, connect the cooling coil (25a) to the tap water supply, and lead the tap water in a sink through the return connector (25b).

A specific water flow rate of 45 ml/minute is sufficient to compensate for the characteristic temperature.



Fasten tubing to prevent slipping.

5.4. Temperature application to external systems

The circulator is used for temperature application to external, closed systems (loop circuit).

Order No. Description

8 970 140 Pump set

8 930 008 2 m CR tubing, 8 mm inner dia.

Mounting the pump set:

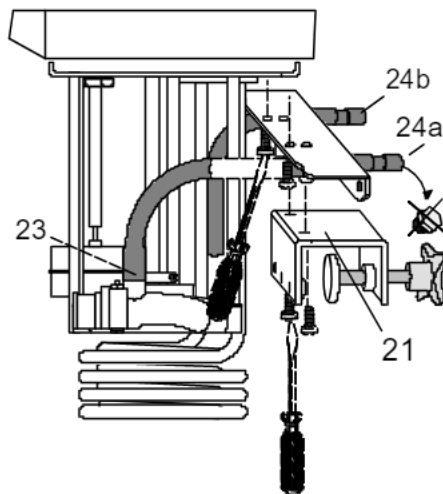

- Remove the bath attachment clamp (21).
- Screw the pump set to the circulator, and then fix the bath attachment clamp to the pump set.
- Slide the short piece of tubing supplied with the pump set onto the short pump nozzle and the pump connector (23).
- Thus the total immersion depth is reduced to 145 mm.
- Adjusting the pump for external bath circulation see example ③ page 10

Connecting an external system:

- Unscrew the collar nuts from the pump connector (24a).
- Slide the tubing onto the pump connectors for feed and return flow (24a, 24b).



Fasten tubing to prevent slipping.

5.5. Adjusting the pump flow

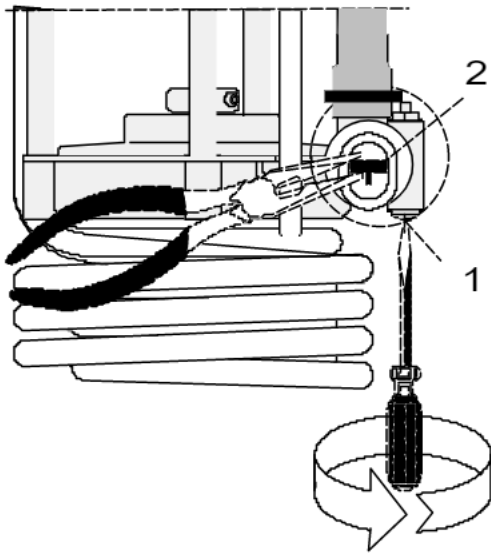

The pump flow is pre-adjusted in the factory and can be modified to suit user requirements.

- Using a screwdriver turn the screw (1) anti-clockwise by 360 °.
- Using flat pliers turn the marking of the slide (2) to the desired position.
- Tighten the screw.

Examples:

Internal applications in the bath

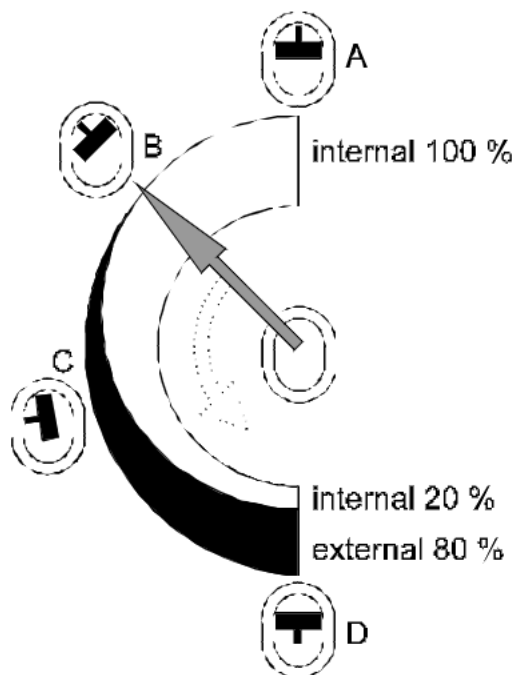

- A 100 % internal bath circulation
(for large bath tanks)
- B Reduced internal bath circulation
(for smooth surface of bath liquid)

External/internal applications

- C 40 % external discharge,
60 % internal circulation
(for large bath tanks)
- D 80 % external discharge,
20 % internal circulation
(for small bath tanks)

6. Operating procedures

6.1. Power connection



Connect the unit only to a grounded mains power socket!
We disclaim all liability for damage caused by incorrect line voltages!

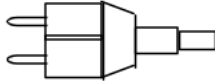
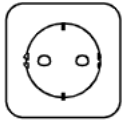

Check to make sure that the line voltage matches the supply voltage specified on the identification plate.
Deviations of $\pm 10\%$ are permissible.

6.2. Switching on / Start - Stop



Switching on:

Turn on the mains power switch.

The unit performs a self-test. All segments of the 4-digit MULTI-DISPLAY (LED) and all indicator lights will illuminate.



Then the software version (example: n 1.0) appears.
The display "**OFF**" indicates the unit is ready to operate (standby mode).

Start:

- Press the start/stop key.
- The MULTI-DISPLAY (LED) indicates the actual bath temperature. (example: 21.0 °C)
- An illuminated indicator light in the "T1" or "T2" key indicates the activated working temperature.



Stop:

- Press the start/stop key.
- The MULTI-DISPLAY (LED) indicates the message "OFF".





The unit also enters the safe operating state "OFF" after a mains power interruptance. The temperature values entered via the keypad remain in memory. With the circulator in keypad control mode, press the start/stop key to restart operation.

NOTE:



The circulator has been configured and supplied by JULABO according to N.A.M.U.R. recommendations. This means for the start mode, that the unit must enter a safe operating state after a power failure (non-automatic start mode). This safe operating state is indicated by „OFF“ or „rOFF“, resp. on the MULTI-DISPLAY (LED). A complete shutdown of the main functional elements such as heater and circulation pump is effected simultaneously.

Should such a safety standard not be required, the AUTOSTART function (automatic start mode) may be activated, thus allowing the start of the circulator directly by pressing the mains power switch or using a timer.

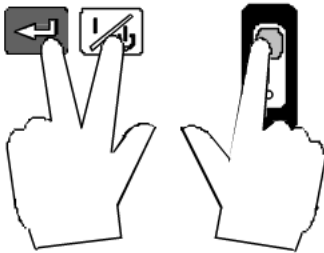
Automatic / non-automatic start mode



Activating/deactivating AUTOSTART

- 1 Keep depressed enter  and the start/stop key 
- 2 and turn on the circulator with the mains power switch.

For a short while the MULTI-DISPLAY indicates the effective start mode:



⇒ AUTOSTART on.

⇒ AUTOSTART off.



Warning:

For supervised or unsupervised operation with the AUTOSTART function, avoid any hazardous situation to persons or property. The circulator does no longer conform to N.A.M.U.R. recommendations.

Take care you fully observe the safety and warning functions of the circulator.

6.3. Setting the temperatures



Take care of the limited temperature range for use with plastic bath tanks.

The working temperature range is stated in the technical specifications (see page 20).

Observe the manufacturer's instructions when using plastic bath tanks.

Safety is only provided with the correct setting of the excess temperature protection (see page 15).

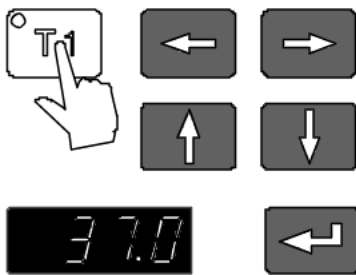

Setting the working temperature "T1":

- ① Press the setpoint key **T1**.
The indicator light **blinks** and the value previously set appears on the MULTI-DISPLAY (LED).
- ② Use the cursor keys to move left or right on the display until the numeral you wish to change is blinking.
- ③ Use the increase/decrease arrows to change the selected numeral (-, 0, 1, 2, 3, ... 9).
- ④ Press enter to store the selected value (example: 37.0 °C).

The working temperature is maintained constant after a short heat-up time (e. g. 37.0 °C).

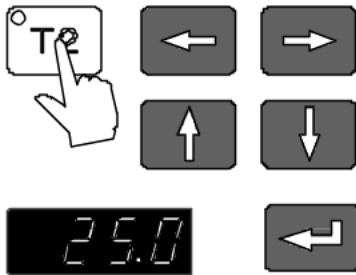

Setting the working temperature "T2":

- ① Press the setpoint key **T2**.
- ② Same procedure
- ③ as with "T1"
- ④ (example: 25.0 °C).

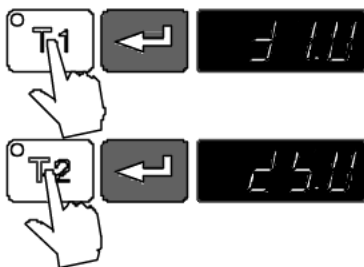

Selecting the working temperature:

- Press the setpoint key **T1** or **T2** and then enter .

6.4. Warning functions

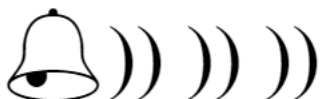

More protection for your samples in the bath!
An audible signal sounds in intervals when the actual temperature value exceeds one of the set limits (patented).

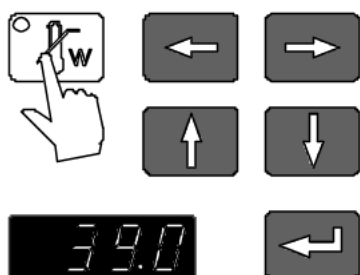

Setting the high temperature limit:

- ① Press the key . The indicator light **blinks** and the value previously set appears on the MULTI-DISPLAY (LED).
- ② Use the cursor keys to move left or right on the MULTI-DISPLAY (LED) until the numeral you wish to change is blinking.
- ③ Use the edit keys to increase or decrease the numeral value (-, 0, 1, 2, 3, ... 9).
- ④ Press enter to store the value (example: 39.0 °C).

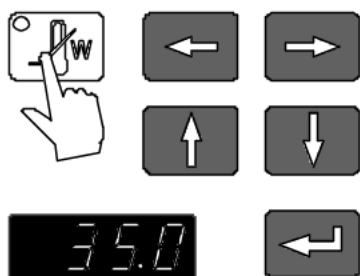

Setting the low temperature limit:

- ① Press the key .
- ② Follow the instructions
- ③ for
- ④ (example: 35.0 °C).



Note: The warning functions will only be triggered when the actual bath temperature, after start from the „OFF“ or „rOFF“ mode, lies within the set limits for 3 seconds.

6.5. Safety installations (with shutdown function)

(excess temperature protection / low liquid level protection)

These safety installations are independent of the control circuit. When the temperature of the bath liquid has reached the safety temperature or the liquid level is insufficient, a complete shutdown of the heater and pump is effected.



The alarm is indicated by optical and audible signals (continuous tone) and on the MULTI-DISPLAY (LED) appears the error message "Error 01".

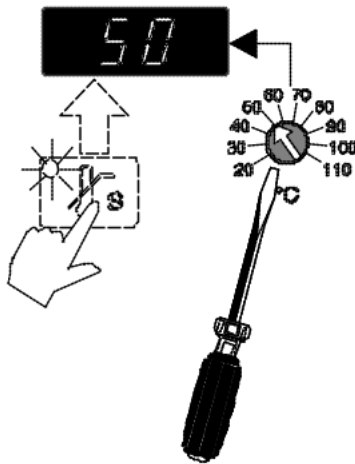

1. Excess temperature protection

- Press the key to indicate the safety temperature value on the MULTI-DISPLAY and using a screwdriver simultaneously turn the setting screw to the desired value (example: 50 °C).

Setting range: 20 °C to 110 °C
in 2 °C steps

Recommendation:

Set the safety temperature at 5 to 10 °C above the working temperature setpoint.

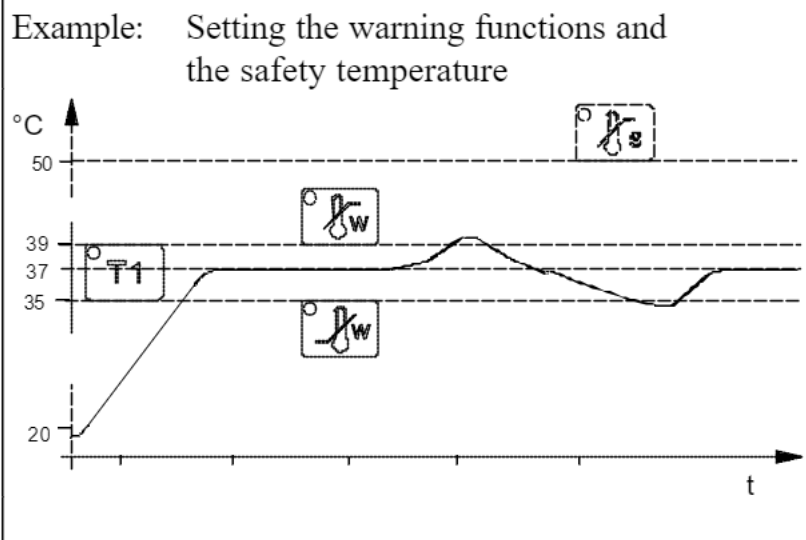

2. Low liquid level protection

This device is triggered when the float reaches a fixed minimum liquid level.

7. Troubleshooting guide / Error messages

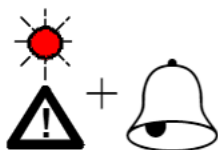

Whenever the microprocessor electronics registers a failure, a complete shutdown of the heater and circulation pump is performed. The alarm light "⚠" illuminates and a continuous signal tone sounds.



Cause

- The circulator is operated without bath liquid, or the liquid level is insufficient.
- The float is defect (e. g., because damaged in transit).
- The safety temperature value lies below the working temperature setpoint.
- A heat reaction or sudden temperature increase, e.g. caused by an exothermic chemical reaction or by the immersion of preheated samples.

Remedy

- Replenish the bath tank with the bath liquid.
- Repair by authorized JULABO service personnel.
- Set the safety temperature to a higher value.
- Set the safety temperature to a higher value.



- The wires of the working temperature sensor are interrupted or short-circuited.



- Defect of the working or safety temperature sensor. The difference between the working temperature and safety sensors is above 25 °C.



} other errors
□
}



After eliminating the malfunction, press the mains power switch off and on again to cancel the alarm state. If the unit cannot be returned to operation, contact an authorized JULABO service station.

Disturbances that are not indicated.

Pump motor overload protection

- The pump motor is protected against overloading. After a short cooling interval, the motor will automatically start running.

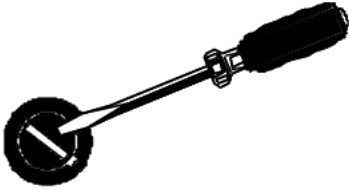

Mains fuses

- The mains fuses on the rear of the unit may easily be exchanged as shown on the left.

(Fine fuse T 10.0 A, dia. 5 x 20 mm)



Only use fine fuses with a nominal value as specified.

8. Safety recommendations

Follow the safety recommendations to prevent damage to persons or property. Further, the valid safety instructions for working places must be followed.



- Connect the unit only to a grounded mains power socket!
- Ensure secure attachment of heating immersion circulators.
- Exercise caution when emptying hot bath liquids!
- Operation is permitted with **non-flammable** liquids only.
- Some parts of the bath cover and the pump connections may become extremely warm during continuous operation. Therefore, exercise particular caution when touching these parts.
- Observe the limited working temperature range when using plastic bath tanks.
- Before cleaning the unit, disconnect the power plug from the mains socket.
- Employ suitable connecting tubing.
- Make sure that the tubes are securely attached.
- Avoid sharp bends in the tubing, and maintain a sufficient distance from surrounding walls.
- Regularly check the tubing for material defects (e.g. for cracks).

9. ATC - Absolute Temperature Calibration



Circulator (T_T)



Measuring point
(T_M)





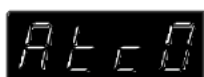







ATC serves to compensate a temperature difference that might occur between circulator and a defined measuring point in the bath tank because of physical properties.

The difference temperature is determined ($\Delta T = T_M - T_T$) and stored as correcting factor (example $\Delta T = -0.2 \text{ }^\circ\text{C}$).







- Press the cursor key  and enter  **at the same time.**
- The MULTI-DISPLAY (LED) indicates "Atc0".
- With the edit keys   select "Atc1" and then press enter .
- Using the cursor keys   and the edit keys   set the correcting factor (example $-0.20 \text{ }^\circ\text{C}$) and then press enter .
- Press  and  **at the same time.**



Measuring point
(T_M)

The temperature on the measuring point rises to a temperature of $37.0 \text{ }^\circ\text{C}$ and is indicated on the MULTI-DISPLAY (LED).



Note:

The correcting factor always affects the actual working temperature, even if this is set via the interface.



The ATC function stays activated until resetting to $00.00 \text{ }^\circ\text{C}$.



Recommendation:

In case a calibrated temperature measuring instrument is used, the ATC function allows the circulator to be used as testing instrument according to DIN/ISO 9000.

10. Cleaning the unit



Before cleaning the unit, disconnect the power plug from the mains socket!

For cleaning the bath tank and the immersed parts of the circulator, use low surface tension water (e.g., soap suds). Clean the outside of the unit using a wet cloth and low surface tension water.



Prevent humidity from entering into the circulator.

11. Maintenance

The circulator is designed for continuous operation under normal conditions. Periodic maintenance is not required.

The tank should be filled only with a bath liquid recommended by JULABO. To avoid contamination, it is essential to change the bath liquid from time to time.

Repairs

Before asking for a service technician or returning a JULABO circulator for repair, please contact an authorized JULABO service station.

When returning a unit, take care of careful and adequate packing. JULABO is not responsible for damages that might occur from insufficient packing.



JULABO reserves the right to carry out technical modifications with repairs for providing improved performance of a unit.

12. Technical specifications

Working temperature range	°C	22 ... 100
with tap water cooling	°C	20 ... 100
Temperature stability	K	±0,02
Temperature selection		digital, via keypad
Temperature indication		MULTI-DISPLAY (LED)
Resolution	K	0,1
ATC - Absolute Temperature Calibration	K	±3
Temperature control		PID
Working temperature sensor		PTC
Safety sensor		PTC
Heater wattage	(at 230 V) W	2000
or	(at 115V) W	1000
Circulation pump:		
pressure, max. at 0 l	mbar	130
discharge, max.at 0 mbar	l/min	10
Usable bath depth	mm	from 80 to 165
Total immersion depth	mm	reduceable from 165 to 145
Overall dimensions (WxDxH)	mm	120x150x320
Weight	kg	2,4
Ambient temperature	°C	5... 40
Mains power connection ±10 % (at 230 V) V/Hz		230 / 50
or	(at 115V) V/Hz	115 / 60
Total power consumption	(at 230 V) W	2070
or	(at 115V) W	1070

All measurements have been carried out at:

rated voltage and frequency ambient temperature: 20 °C
bath liquid: water operating temperature: 70 °C

Technical changes without prior notification reserved.

<u>Safety Installations (DIN 12876)</u>	
Excess temperature protection	adjustable from 20 to 110 °C
Low liquid level protection	float switch
Safety class	1
<u>Supplementary safety installations:</u>	
High temperature warning function	optical + audible (in intervals)
Low temperature warning function	optical + audible (in intervals)
Supervision of the working sensor	plausibility control
Reciprocal sensor monitoring between working and safety sensors	difference >25 °C
Alarm indication	optical + audible

<u>Standards</u>	
EMC regulations	EN 61326
Guideline for first voltage range	EN 61010

13. EC Declaration of Conformity



The following unit complies with the essential safety requirements outlined by the EC Directives concerning the guidelines for electromagnetic compatibility (89/336/EEC) and for the low voltage regulations (73/23/EEC).

Heating Immersion Circulator: MP

This unit is manufactured in compliance with the following guidelines

electrical equipment for control technology and laboratory application –
EMC requirements outlined by

EN 61326

safety regulation for electrical devices for measuring, control and
laboratory application specified by

EN 61010

Julabo

Julabo Labortechnik GmbH
Eisenbahnstr. 45
D-77960 Seelbach / Germany

A handwritten signature in black ink, appearing to read 'G. Juchheim', written in a cursive style.

G. Juchheim, Managing Director

14. Warranty conditions

JULABO Labortechnik GmbH warrants its products against defects in material or in workmanship, when used under appropriate conditions and in accordance with appropriate operating instructions for a period of no less than

ONE YEAR

Extension of the warranty period – free of charge



With the '1PLUS warranty' the user receives a free of charge extension to the warranty of up to 24 months or 10.000 working hours; whichever is achieved first.

To apply for this extended warranty the user must register the unit on the Julabo web site www.julabo.de, indicating the serial no. The extended warranty will apply from the date of Julabo Labortechnik GmbH's original invoice.

Julabo Labortechnik GmbH reserves the right to decide the validity of any warranty claim. In case of faults arising either due to faulty materials or workmanship, parts will be repaired or replaced free of charge, or a new replacement unit will be supplied.

Any other compensation claims are excluded from this guarantee.